

FUORIPISTA

BIKE

Bike interactive stationary bike

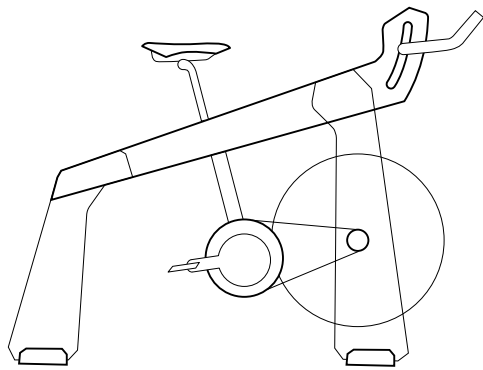

120 cm

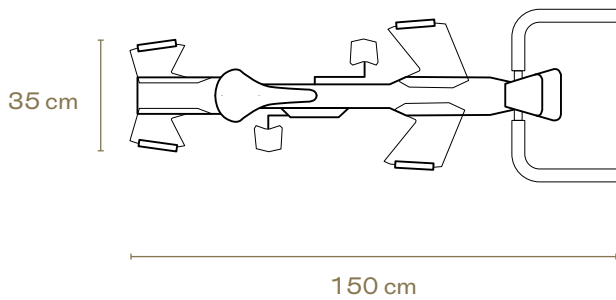

35 cm

60 cm

150 cm

Iconic and uncommon, as the name suggests.

The perfect combination of accuracy, interactivity and cutting-edge design.

Elite introduces Fuoripista, The Interactive Stationary Bike created in cooperation with Adriano Design.

Fuoripista features integrated power meter and virtual shifter - it also ensures great compatibility with My E-Training and all the other indoor cycling software on the market that electronically manage resistance, so you can experience a really complete training session in synergy with the most refined components that the "Made in Italy" has to offer.

Max load bearing		110 kg
Max slope simulated	60 rpm and exchange ratio 30-28	25 %
Resistance levels		16
Power meter accuracy		± 2,5 %
Power supply required		10 h

# TECHNICAL SPECIFICATIONS

---

## A SOPHISTICATED MADE IN ITALY DESIGN

Fuoripista stems from a study on indoor training adapted to home living by Adriano Design, a well established design studio from Turin that cooperated with Elite to design this luxury smart bike.

Fuoripista was created to engage a style vision that is still a hallmark for Made In Italy worldwide, integrating exclusive furnishings to our catalogue of technological innovations for indoor cycling.

This is clear right away from its elegant structure, a sophisticated combination of high quality sturdy materials: tempered glass, ash wood, aluminium and leather.



---

## HIGH QUALITY MATERIALS

This luxury smart bike is supported by four sturdy multilayered and tempered glass legs, perfect for sprints as they ensure maximum resistance to efforts and mechanical stresses.

The big 50 cm / 15 kg flywheel is also made of glass - it's one of the biggest flywheels in indoor training and the ideal instrument for an hyper-realistic pedalling simulation, especially when developing a high power output.

The main lintel is covered by closed-pore painted ash wood, treated to resist sweat drops that develop during intense training sessions.

The aluminium alloy is used to house the resistance unit, adjusted by felt brake pads, and shape the height-adjustable seat post.

The handlebar - leather-covered just like the saddle - is also height-adjustable via the front knob.

---

## VIRTUAL SHIFTER, GUARANTEED POWER

The two levers used to adjust resistance are also in aluminium alloy - an intuitive way to virtually shift gears and manage the front and rear gears of the bicycle, as if you were on the road.

When used in the Simulation or ERG mode you can increase or decrease the target power with the right lever and select up to 16 resistance levels with the left one.

These two levers that adjust resistance are also useful in the standalone mode.

What makes this luxury object a perfect and effective training instrument is also the integrated magnetic technology power meter that picks up power output with  $\pm 2,5\%$  accuracy.

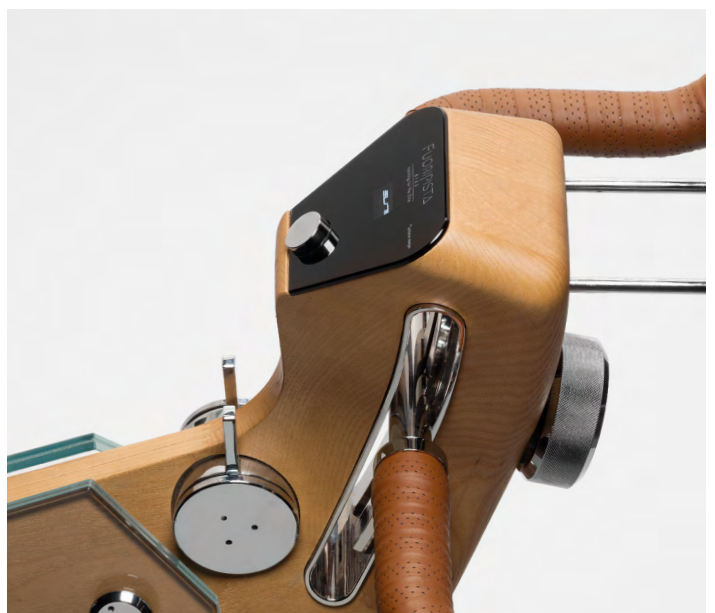

## TOTALLY INTERACTIVE

Just as in the Elite interactive hometrainers, the Fuoripista electronically manages resistance via the double ANT+™ FE-C, PWR, S&C and Bluetooth communication protocols - this smart bike wirelessly interacts with any app, software, computer, cycle computer, smartphone and tablet on iOS, Android, MacOS and Windows.

That's why Fuoripista can be interfaced with the Elite My E-Training software (includes a free 36-month subscription), with

Zwift and all other indoor cycling platforms such as TrainerRoad, Kinomap, Rouvy, The Sufferfest, Bikevo and many more.

Fuoripista also includes a rechargeable lithium battery with provided power supply and 10 hrs autonomy, so you can always enjoy wire-free training sessions.

Control via:



Wireless communication:



Compatible with:

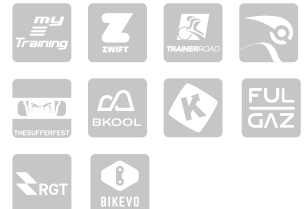

## ACCESSIBLE TECHNOLOGY

The structure of the Fuoripista includes a monitor where you can manage connectivity, modes, power output, brake calibration and check out battery and gear shifter status in an intuitive and accessible way.

Moreover, the unit also houses an emergency button in its central section of the console that can be activated in case of necessity to intervene directly on the brake and place the training session in standby for 10 seconds.

The unit also features a support for any tablet of your choice.

- 1 Battery status (remaining amount of charge or if charging)
- 2 Connection indicator (ANT + / Bluetooth)
- 3 Operating modes
- 4 LEV (levels)
- 5 ERG (ErgMode/power)
- 6 SIM (simulation)
- 7 Power indicator (in watts)
- 8 Virtual gear ratio (only in simulation mode)
- 9 Periodic brake calibration indication
- 10 Other service functions (zero sensor, shoe replacement, firmware update).

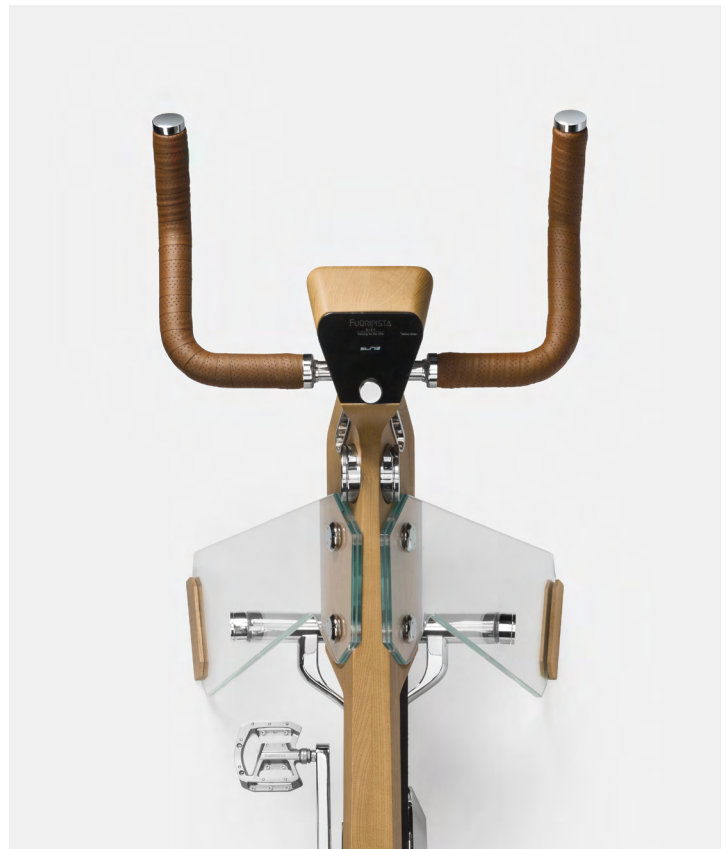

**ELITE**

Elite srl  
via Fornaci, 4  
35014 Fontaniva  
Padova – Italy

www.elite-it.com  
www.fuoripista.it